

## Wall Hung Ceramic sinks



### Installation Instructions and Operation Manual Effective 2020

**Installer: This booklet must be given to the product owner.**

**Please note important information below:**

Distributor Name & Location: \_\_\_\_\_  
Model Number: \_\_\_\_\_  
Date of Purchase: \_\_\_\_\_

## Owner's Manual and Installation Guide

Thank you for choosing a Hastings Ceramic sink. You have purchased a product designed and manufactured in Italy. We know it will give you many years of pleasure. The instructions in this booklet will provide you with the information you need to install and operate this unit. This information is also available online at [www.hastingstilebath.com](http://www.hastingstilebath.com). Our customer service department is available to answer any additional questions you may have relating to the installation and operation of your Vanity. Call 800-351-0038 to speak to our Customer Service representative. Please have your model number and order information available when calling.

## Important Safety Instructions

**Warning: When using this product, basic precautions should be followed as noted below:**

This manual contains information and instructions for proper operation and maintenance of your Hastings sink. Failure to follow these instructions could result in personal injury.

## Read and Follow All Instructions

### Instructions Regarding Risk of Personal Injury

- ▶ Do not permit children to use this unit unless they are closely supervised by an adult at all times.
- ▶ Use this unit only for its intended use as described in this manual. Do not use attachments not authorized by the manufacturer.

**DANGER:** To reduce the risk of injury, never sit or stand on the wall hung sink..

**INSTALLER/OWNER BEARS ALL RESPONSIBILITY TO COMPLY WITH ALL STATE AND LOCAL CODES WHEN INSTALLING THIS PRODUCT**

**Caution:** Do not use harsh abrasives or solvents for cleaning this unit.

- ▶ This product is intended for residential indoor use only. It is only warranted for indoor installation in a climate controlled environment.
- ▶ Do not store at temperatures below 32 degrees Fahrenheit.

# SAVE THESE INSTRUCTION

## Unpacking the Unit

1. Inspect the Carton.
2. If you note carton damage, take a picture, note the delivery receipt as damaged and contact the dealer or Hastings immediately. **Do not install a damaged product. Hastings is not responsible for damage during transit.**
3. Immediately inspect the unit for damage even if there is no visible carton damage and immediately report any damage to the distributor or manufacturer customer service at 1-800-351-0038. Once the unit is installed and there is surface damage visible, we will assume it was caused by the installer. Installers are responsible for damage that occurs once the unit is set in place. Installation constitutes acceptance.
4. Remove all packaging material except for the protective foam covering. The protective foam covering was put on the product to help eliminate abrasions due to handling and should not be removed until you are ready to inspect or just prior to installation.

## Installation and Operation Guidelines

Read all instructions before installing the product. Installer/product owner is responsible for complying with all state and local codes. Hastings strongly recommends using licensed professionals to install these products. **Warning: Certain cleaning products will permanently damage the cosmetic surface of the product. Read cleaning product instruction carefully before using. Never use anything abrasive, aerosol sprays, or metal scrapers.**

### **BEFORE INSTALLING:**

Remove the protective plastic and inspect the product thoroughly. The protective plastic was put on the product to help prevent abrasions/staining, and the cosmetic surface of the product should be protected in some manner after the protective plastic is removed. A factory defect must be reported to the manufacturer before the product is installed. Defects or damage claimed after installation will be excluded from the warranty.

**Important:** Measure the product on site carefully. Hastings is NOT responsible for any preparatory labor or materials.

**Warning:** Some Ceramic sinks may be very heavy. Make sure you have adequate help to move/install them before beginning. Hastings is not responsible for handling damage.

# ATTENTION INSTALLER!

Always protect the product from construction damage. Damage, including chips and scratches, incurred at the jobsite is excluded from the warranty, but may be repaired by a qualified individual at the owner's expense.

**Important:**

## Installation Planning and Preparation

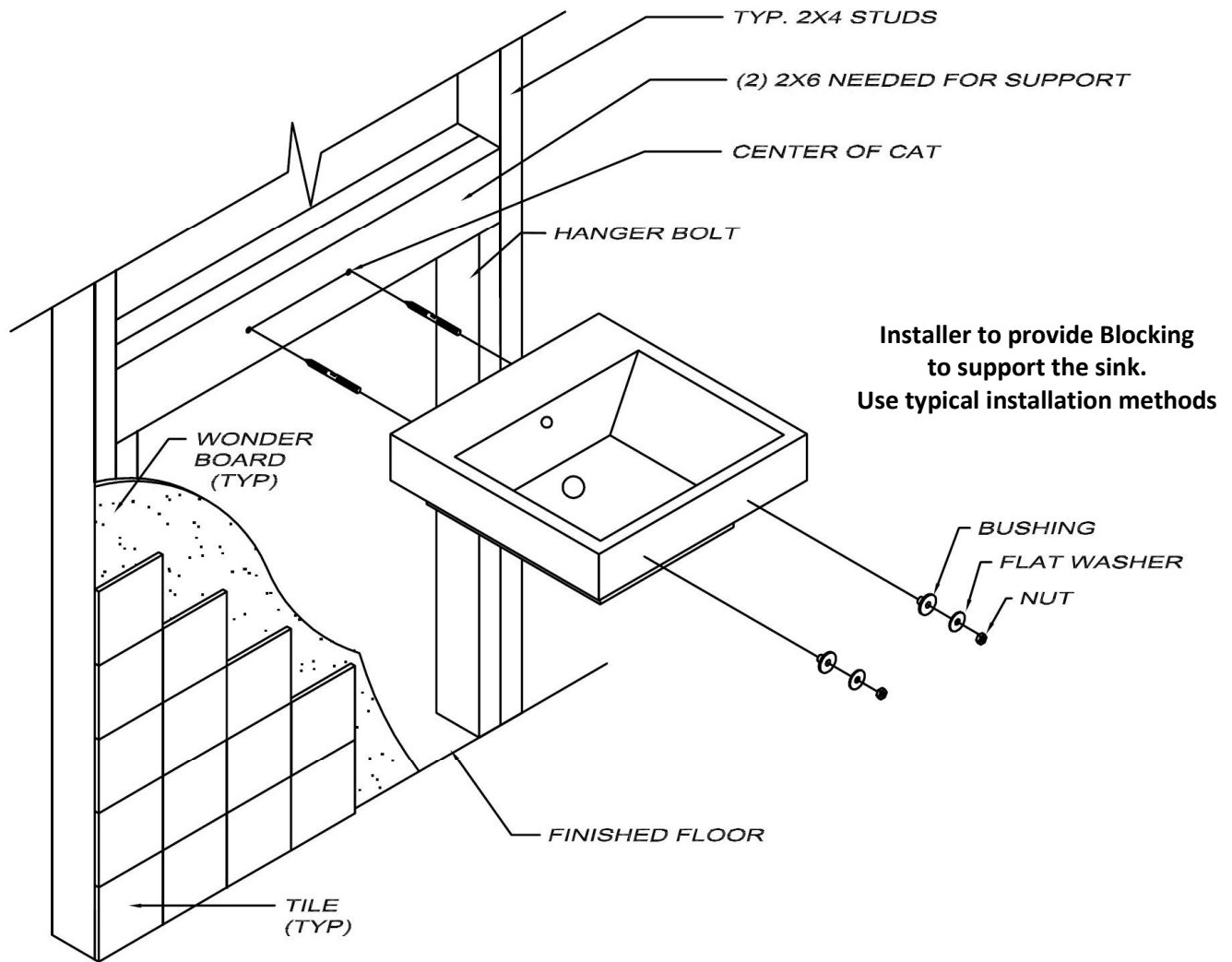

Typical tools needed provided by installer

- **Rough plumbing below should be confirmed with the plumbing parts purchased and sold separately, your plumbing products may require other rough in locations.**
- **Sink size details can be found on the product Spec sheet.**

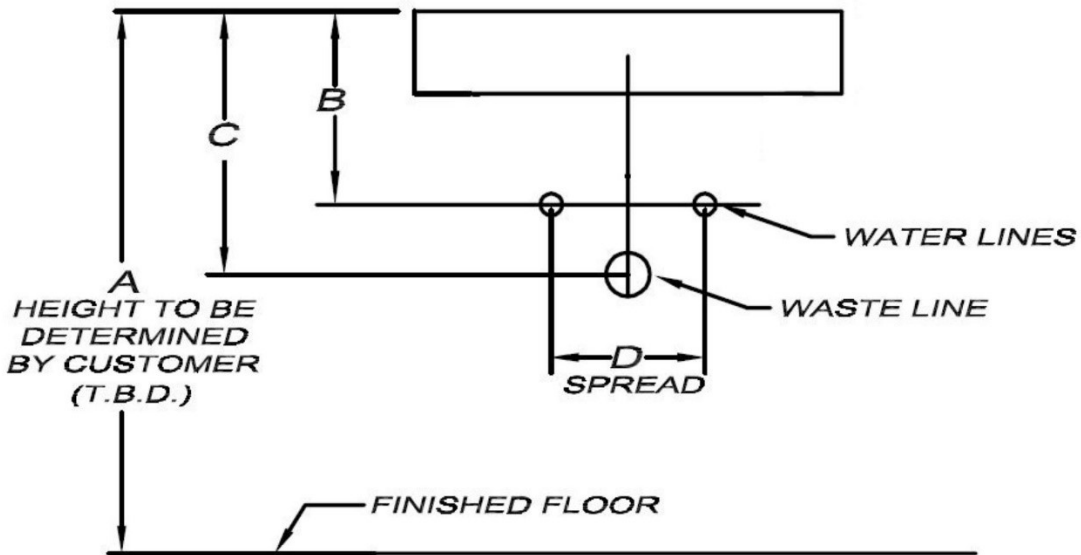

FITTINGS	A	B	C	D
Wall Hung	T.B.D.	9"	13"	4"-8"

- Check to make sure the wall is flat with no belly or wave in the wall material. All wall material should be flat and permanently bonded. Any tile should be left to dry for a week before installing the vanity.
- For tile or stone walls, a hammer drill and masonry drill bit may be needed



- Locate the top of the sink and the center of the sink aligned with the drain location on the wall.
- Mark the wall with the sink position and measure to locate the wall mount holes in the sink, double check all measurements and transfer measurements to the wall.
- Drill and attach the hanger bolts securely to the wall blocking as shown above

## INSTALLING THE SINK

- It is recommended to install the faucet onto the sink before the top is placed on the wall.

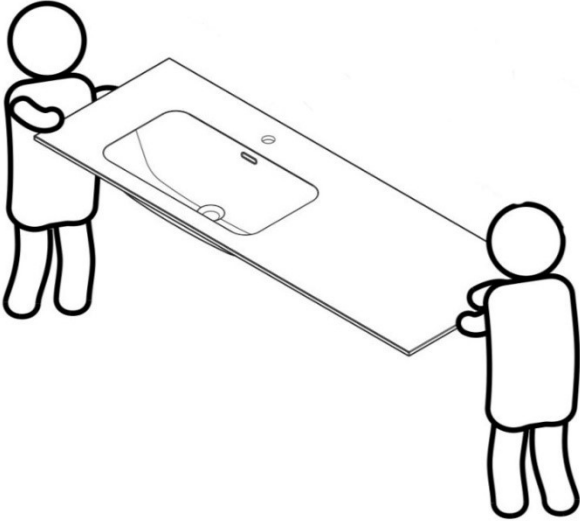

- With two people lower the sink in place taking care to center it.
- Install washers and nuts onto the hanger bolts and snug it to the wall.
- Use a level to level the sink and then tighten all nuts permanently.
- Install the Plumbing and drain using standard plumbing practices. Note: It is recommended to use clear silicone as your drain seal as plumbers' putty may damage some finishes.

## **Cleaning Instructions for Ceramic Tops**

The Hastings Products ceramic glaze is one of the highest quality surfaces available. The finish is designed to provide an elegant, durable finish. Its hard, non-porous surface prevents dirt from accumulating and resists stains. Under normal use, the ceramic surface will retain its beauty with only a minimal amount of care. To maintain the elegant look, follow these simple steps:

**Construction Debris:** Most construction debris can be removed with a mild detergent. Plaster can be removed by carefully using a sharpened wooden stick. **Do not use metal scrapers, wire brushes, or other harsh abrasive tools.**

Remove dust and dry dirt with a soft, damp cloth. To remove most stains, use Mr. Clean Magic Eraser. Clean grease, oil, paint, or ink stains with isopropyl (rubbing) alcohol. Dry with a clean, soft cloth.

Avoid using razor blades or other sharp objects that might scratch the surface.

Only use nonabrasive cleaners, no alcohol or ammonia cleaners should ever be used. Always dry with a soft lint free cloth.



## LIMITED WARRANTY

All Hastings Ceramic Sinks are warranted in accordance with the following Limited Warranty:

Hastings Ceramic Sinks are warranted against defects in material and workmanship from the date of the first consumer purchase.

The manufacturer warranty is 1 year against defects. This Warranty shall apply to defective surfaces which crack, fade or blister.

The Warranty extends to the first consumer purchaser and not to subsequent owners, transferees or users other than the first purchaser. This warranty does not extend to products previously utilized as display models.

This Warranty shall apply to products installed and used only for indoor personal, family or household purposes and which are installed and maintained in accordance with Hastings recommended installation and maintenance procedures. This Warranty does not extend to defects or damage caused, in whole or in part, by any unauthorized or unreasonable use such as misuse, abuse, negligence or accidental damages resulting from customer or installer. No liability shall exist for incidental or consequential damages caused in whole or part by any defects in Hastings products. No warranty, expressed or implied, including any warranty of merchantability or fitness for a particular purpose, shall apply after the warranty period described above. Some states do not allow the exclusion or limitation of incidental or consequential damages or limitations on how long an implied warranty last. The above limitation may not apply to you.

In the event of a defect in material or workmanship of a Hastings Bath distributed product during the Warranty period, defective products will be repaired or replaced by Hastings, at its sole and absolute discretion. However, Hastings shall not be liable for the expense for removing defective products or installing replacement products. In certain circumstances, some states do not allow the limitation of liability for removal, transportation and reinstallation expenses. The above limitation may not apply to you.

Only Hastings is authorized to perform its warranty obligation. If you wish to obtain performance of the Hastings warranty obligation you should contact Hastings, telephone number 800-351-0038. Other information about performance of the Hastings warranty obligation may be obtained at the same address and telephone number.

This Warranty gives you specific legal rights and you may also have other rights which vary from state to state.

For Warranty claims contact Hastings tile and Bath;  
711-8 Koehler avenue Ronkonkoma, NY 11779 - 1-800-351-0038 - email [cs@hastingstilebath.com](mailto:cs@hastingstilebath.com)